

MOUNTING, OPERATING AND MAINTENANCE INSTRUCTIONS



TABLE OF CONTENTS

1. GENERAL	1
2. STRUCTURE OF A VALVE	2
3. MARKINGS OF A VALVE	6
4. ACCEPTANCE AND STORING	7
5. MOUNTING AND COMMISSIONING	7
6. MAINTENANCE.....	10
7. DECOMMISSIONING	12
ANNEX A: VALVE WITH EDGE SEALING	13
ANNEX B: VALVE WITH LIGHT SEALING	14
ANNEX C: VALVE WITH STANDARD SEALING.....	15
ANNEX D: VALVE WITH STELLITE SEALING	16

The manual is designed to be as complete and accurate as possible. Jouka Ltd reserves the right to change the contents of this manual without notice. In conflicting situations, the English manual is valid. Jouka Oy is not responsible for any errors or deficiencies in this manual.

1. General

This instruction is general and does not cover all special cases. We as a manufacturer are glad to guide you, so do not hesitate to contact us. Jouka Oy is not responsible for the consequences caused by ignoring these instructions.

Warning signs, attention signs and recycling signs have been added to the instruction:



Warning sign points your attention to things that cause serious danger



Attention sign points your attention to things that cause possible danger



Recycling sign guides you towards environmentally sound actions

2. Structure of a valve

Jouka Oy manufactures ball valves with floating ball. The body of Jouka-valve is not casted. Numerous joint options are available. Rough visualization of the structure of steel, aluminium and valve with stellite sealing are presented below.

Steel valve

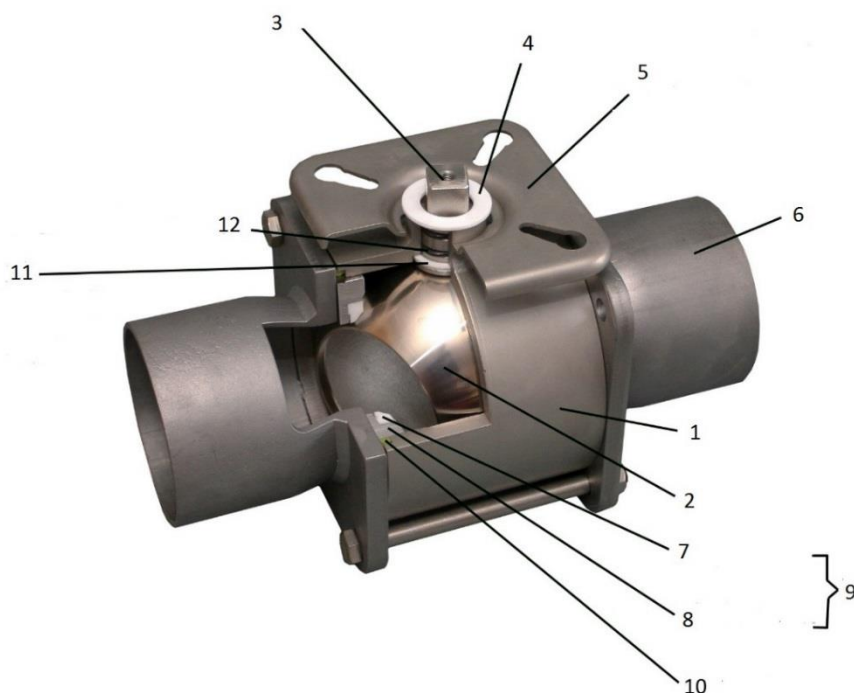

- | | | |
|---|--------------------------|-------------------|
| 1. Body | 7. Seat | } 9. Ball sealing |
| 2. Ball | 8. Seat support | |
| 3. Anti-blowout stem | 10. O-ring (flange seat) | |
| 4. Washer of hand lever/ actuator | 11. Bearing | |
| 5. ISO 5211 connection plate for actuator | 12. O-rings of stem | |
| 6. Joint | | |

Aluminium valve

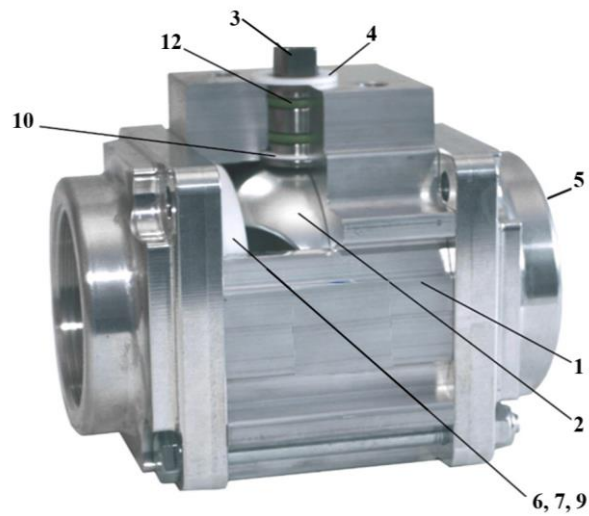

- | | | |
|-----------------------------------|-------------------------|-------------------|
| 1. Body | 6. Seat | } 8. Ball sealing |
| 2. Ball | 7. Seat support | |
| 3. Anti-blowout stem | 9. O-ring (flange seat) | |
| 4. Washer of hand lever/ actuator | 10. Bearing | |
| 5. Joint | | |

Valve with stellite seals

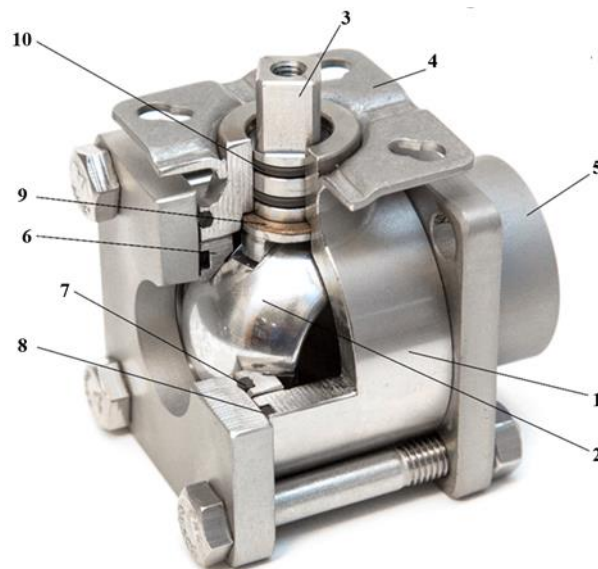

- | | |
|---|--------------------------|
| 1. Body | 6. Ball seats (stellite) |
| 2. Ball | 7. Pressure ring |
| 3. Anti-blowout stem | 8. O-ring (flange seat) |
| 4. ISO 5211 connection plate for actuator | 9. Bearing |
| 5. Joint | 10. O-rings of stem |

Table underneath shows the temperature limits of most o-ring and body material combinations. Limits are indicative, so please confirm from our sales engineer that the combination is optimal for your need.

Body material	Sealing material	Temperature min	Temperature max
Aluminium	EPDM	-40 °C	+120 °C
Aluminium	FPM	-20 °C	+120 °C
Aluminium	NBR	-20 °C	+120 °C
Aluminium	PTFE	-20 °C	+180 °C
Duplex	FEPM	-10 °C	+200 °C
Duplex	FPM	-10 °C	+120 °C
EN 1.4404	EPDM	-40 °C	+120 °C
EN 1.4404	FEPM	-10 °C	+160 °C
EN 1.4404	FEPM	-10 °C	+200 °C
EN 1.4404	FPM	-20 °C	+120 °C
EN 1.4404	PTFE	-20 °C	+180 °C
EN 1.4404	EPDM	-40 °C	+120 °C
Steel	EPDM	-40 °C	+120 °C
Steel	FEPM	-10 °C	+160 °C
Steel	FEPM	-10 °C	+200 °C
Steel	FFKM	-10 °C	+300 °C
Steel	FPM	-20 °C	+120 °C
Steel	PTFE	-20 °C	+180 °C

There are three structurally different balls for Jouka-valves. Ball types and possible materials in them are presented in figure 1. Our experts will help you to choose the right ball type.

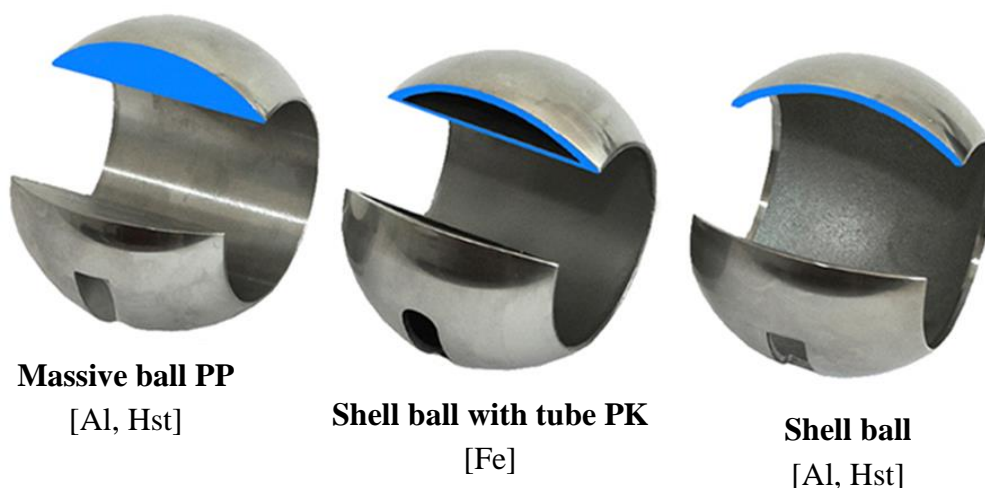

Figure 1. Different structures of Jouka balls. Possible materials are presented within square brackets.

A shell ball with tube PK is available only in size DN100/090.



In the case of shell ball, whirls may occur inside the ball and when installed near hydraulic pump it may cause the pump to cavitate.

If there is a risk of cavitation, then we recommend using a massive PP ball.

Table 2 shows the volumes of the Jouka valves equipped with welding joints.

Table 2.

Nominal size	Volume [liter]
DN15	0,055
DN25	0,149
DN32	0,292
DN50	0,600
DN65	1,020
DN80/65	1,460
DN80/80	1,925
DN100/90	2,910
DN100/100	3,420
DN125	5,796
DN150	8,990
DN200	18,210

3. Markings of a valve

A sticker, with the information presented below, is attached to the body of every valve we manufacture. According to the Pressure Equipment Directive, CE mark is not attached to valves with nominal size of DN032 or smaller.



1. Logo, name and www-address of the manufacturer
2. Country of manufacture
3. Week/year
4. Nominal size, pressure class and type of product
5. CE-mark
6. Body material (sealing material)
7. Temperature limits
8. Serial number: order confirmation number - position - serial number

4. Acceptance and storing



Be aware of the valve's weight when handling it. It is not allowable to lift the valve from actuator or from hand lever.

After delivery has arrived, check that it is equivalent to the order. After receiving you have 14 days to make claim notice. Valves are delivered in open position.



Brown card board boxes to paper board collection. Plastic (not PVC) to waste-to-energy collection. Pallet collars can be re-used.

If you store valves before mounting, do not expose them to weather or dirt. Instead of placing valves directly on the ground, store them in dry and well-ventilated place. Bare steel surfaces ought to be protected with corrosion inhibitors. One option is to pack valves in VCI bag. Remember to ensure the suitability of the VCI product from the supplier of the bags.

5. Mounting and commissioning

Remove any transport/storage protection. We recommend recycling the packing materials.



The valve is suitable only for its planned purpose and it functions only when installed correctly. If you are uncertain, contact manufacturer.

Piping, machine units, containers and other structures to which the valves are connected has to be cleaned before mounting. The rinsing of the pipe system from welding rests has, if any way possible, to be performed before installing the valve. If the piping is rinsed after the valve has been mounted, then the valve must be in open position. This way the biting of metal particles to the surface of metal gasket, and further the scratching of ball is avoided.



Piping must be supported in a way that the valve is not subjected to load and the valve is not predisposed to strong vibration

Valves with hand levers the open position means that the lever is parallel to the joints and closed position means that the lever is vertical with respect to the joints.

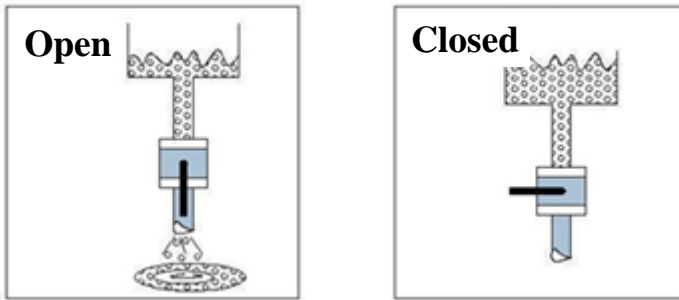

Welding joints

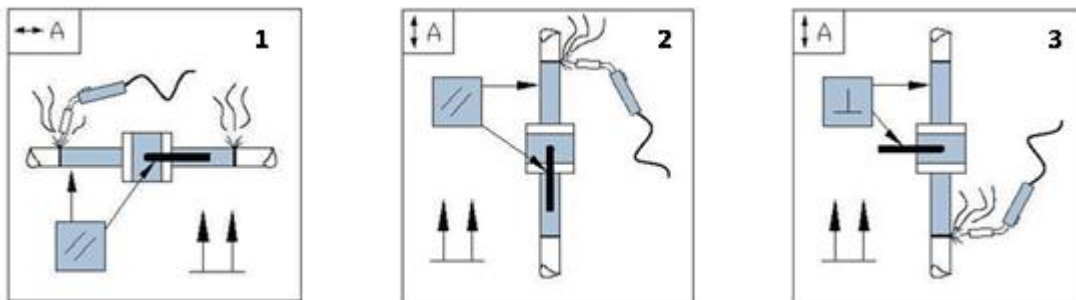

If you are installing the valve to a horizontal piping, make sure that the valve is in open position when you weld the joints to the pipe (picture 1).

If you are installing the valve to a vertical piping, make sure that the valve is in open position when you weld the upper joint to the pipe (picture 2) and in closed position when you weld the lower joint to the pipe (picture 3).

Inside threads

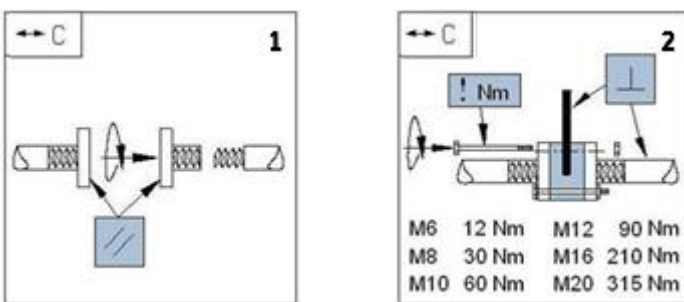

Twist joints to pipes (picture 1). Install the central body between the joints so that you first set all the bolts in their places and tighten nuts only a little (picture 2). Make sure that the body is carefully in line with the flanges and tighten the bolts crosswise. By tightening the bolts located at contradictory corners, you ensure that the central part stays in line and does not turn flanges. Make sure that you do not cross recommended torques presented in table 3.



Valve is not allowed to be the end device of piping, there must always be a solid flange after a valve

Table 3. Torques for different bolt sizes.

Bolt	Torque	Valves
M6	12 Nm	DN010-DN015
M8	30 Nm	DN025-DN050
M10	60 Nm	DN065-DN080
M12	90 Nm	DN100
M16	210 Nm	
M20	315 Nm	

Sample taking valve



1. Mark the hole required by the flange to the pipe.
2. Make the necessary hole in the pipe.
3. Connect the flange to the pipe. Set the flange so that the arching of the flange corresponds to the arching of the inner hole of the pipe. Weld with the method which causes minimum heat or in short pieces and cooling between pieces. Otherwise thinner parts change their form and the valve does not function any more.
4. If you weld the valve to the pipe as whole, remember the same things than above and in addition turn the valve to open position. Pay special attention, so the gaskets and o-rings will not get damaged.

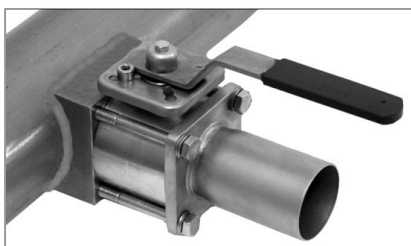

In the pressure test attention must be paid on the nominal pressure (PN) of the valve. When valve is in closed position, maximum 1,1 x PN test pressure is recommended. Higher test pressure may cause molding of the soft ball sealings. When the valve is in open position, test pressure has to be maximum 1,5 x PN.

Jouka Oy is responsible only for those actuators/ switches that have been installed in our factory. Adjustment instructions can be asked from the manufacturer of the actuators. Our experts are glad to provide any additional information.

6. Maintenance



Notice that the surface of the valve may be hot or cold due to the medium in piping. Protect yourself accordingly.

When used right Jouka valves are long-lived and the need for maintenance is minor. It is impossible to define exact maintenance interval because it depends on conditions, on medium, on temperature and on the job circulations of the valve.



We recommend that you regularly open and close valves that are on rare cycles. This helps to prevent oxidation and getting jammed.

If, however you need spare parts for a valve, the information which you need to get the right parts has been listed underneath.

Seal kits

- fluid/ medium type
- operating temperature
- material of the valve
- serial number of the valve
- or the length of valve's central part, B measure
- or the size of the ball, ØD measure

Other components

- serial number of the valve or
 - the length of valve's central part, B measure
 - or the size of the ball, ØD measure
 - size of the square end of the shaft/ size of the square of the shaft
 - for a ball: size of the ball ØD and type of the ball (figure 1)

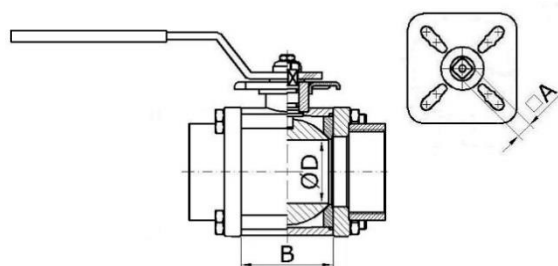



By using only original spare parts you make sure that the valve functions as intended.

Instead of the seal kits we recommend changing the central part in valves with nominal size DN50 or smaller. In small valves, the changing of the central part is much quicker and more reliable solution than dismantling the valve and replacing seals. To valves with metal seals we do not provide seal kits because we want to test the central parts with metal seal for tightness at our own factory.



Do not operate with pressurized piping!

Removing the valve for maintenance

- Turn valve to closed position.



In horizontal piping, it is possible that small amount of medium remains inside of the ball. Notice the hazards related to such medium.

- In smaller valves, one bolt is opened and others are loosened. After that the central part can be removed separately.
- In bigger valves, 2 or 3 bolts are opened and others are loosened. After that the central part can be removed separately.

In the case of painted valves, it is extremely important to clean the surface of the flange carefully. The cleaning must be made from large enough area.



Beware not to scratch the surface of the valve



- When installing the valve back, make sure that there is enough clearance between body and the flanges. In this way, you avoid damaging the seals of flange/ ball.
- Tighten the bolts in right paragraph which are presented in table 3. Do not cross the recommended torque!

In the case of painted valves, the surface which stays outside the body of the valve must be repainted after remounting.



Any additional sealing compounds or glues are **NOT ALLOWED** to be used in any part of the valve

Seal kits include seals for stem, ball and flanges. More detailed illustrations can be found from annex A-D.

7. Decommissioning

Disconnect the valve from the piping by first disconnecting the center part. For more detailed instructions on irrigation of the center part, please see **Removing the valve for maintenance**. Observe again the temperature of the valve surface and the hazards associated with the contents.



Please recycle the used valve properly. For more information, we recommend that you contact your local waste management specialists.

ANNEX A: VALVE WITH EDGE SEALING

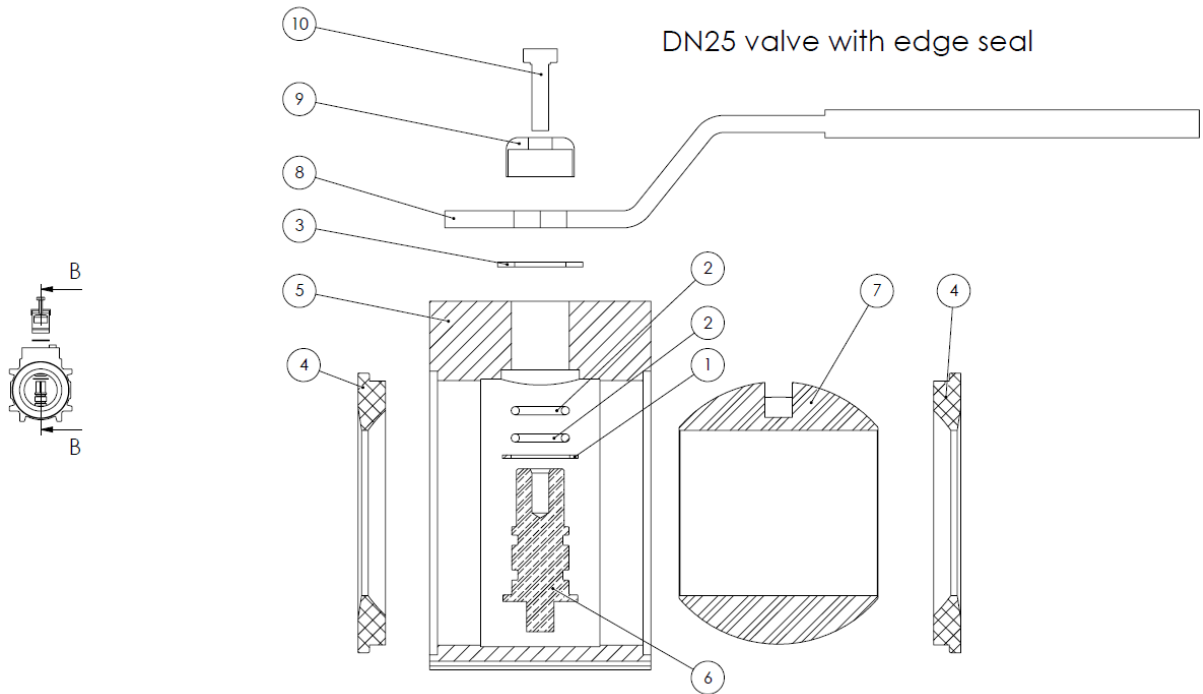

ITEM NO.		QTY.
1	Bearing	1
2	O-ring	2
3	Washer	1
4	Ball seat	2
5	Body	1
6	Stem	1
7	Ball	1
8	Hand lever	1
9	Cup washer	1
10	Locking screw	1

ANNEX B: VALVE WITH LIGHT SEALING

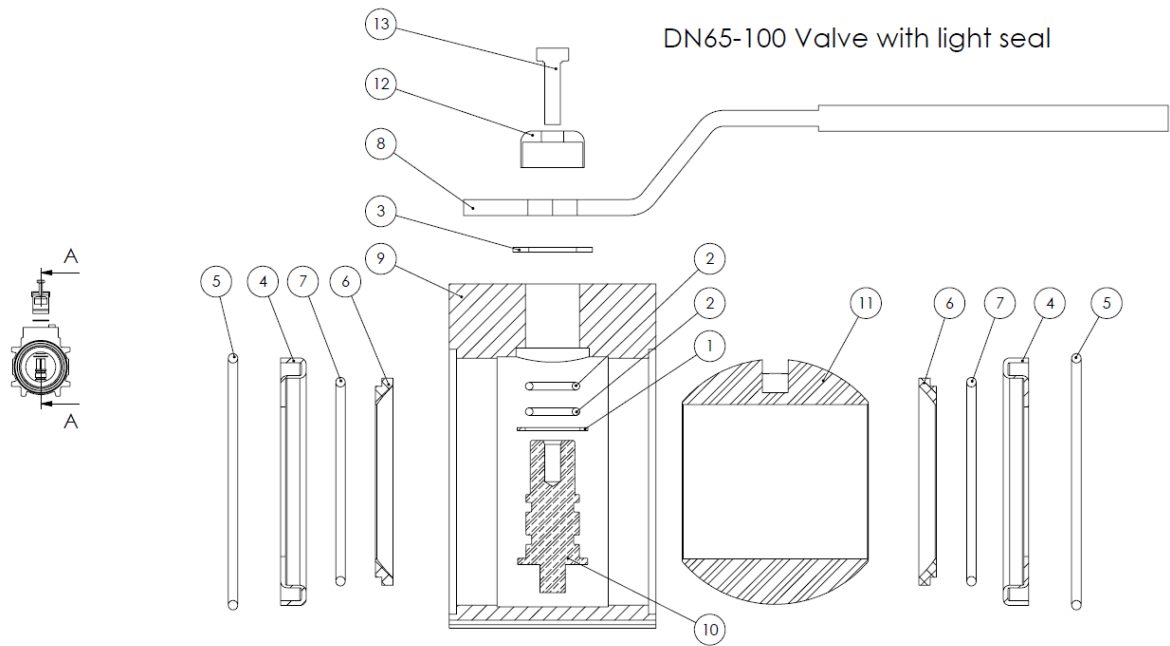

ITEM NO.		QTY.
1	Bearing	1
2	O-ring	2
3	Washer	1
4	Seal support	2
5	O-ring	2
6	Ball seat	2
7	O-ring	2
8	Hand lever	1
9	Body	1
10	Stem	1
11	Ball	1
12	Cup washer	1
13	Locking screw	1

ANNEX C: VALVE WITH STANDARD SEALING

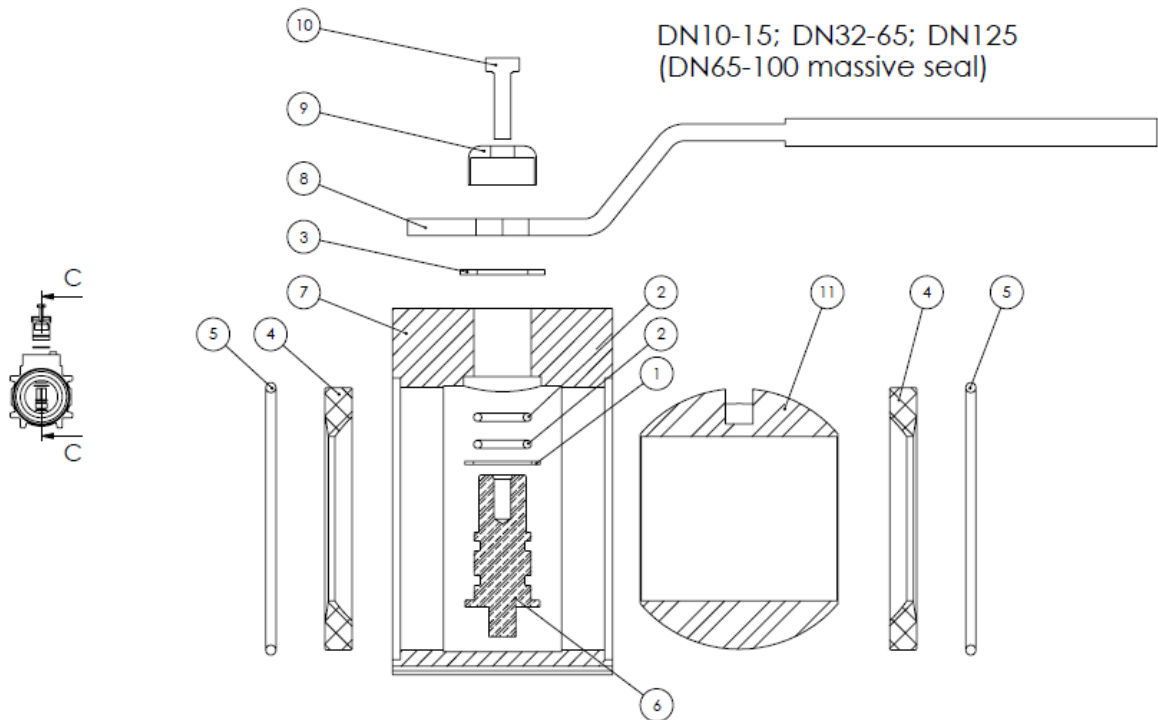

ITEM NO.		QTY.
1	Bearing	1
2	O-ring	2
3	Washer	1
4	Ball seat	2
5	O-ring	2
6	Stem	1
7	Body	1
8	Hand lever	1
9	Cup washer	1
10	Locking screw	1
11	Ball	1

ANNEX D: VALVE WITH STELLITE SEALING

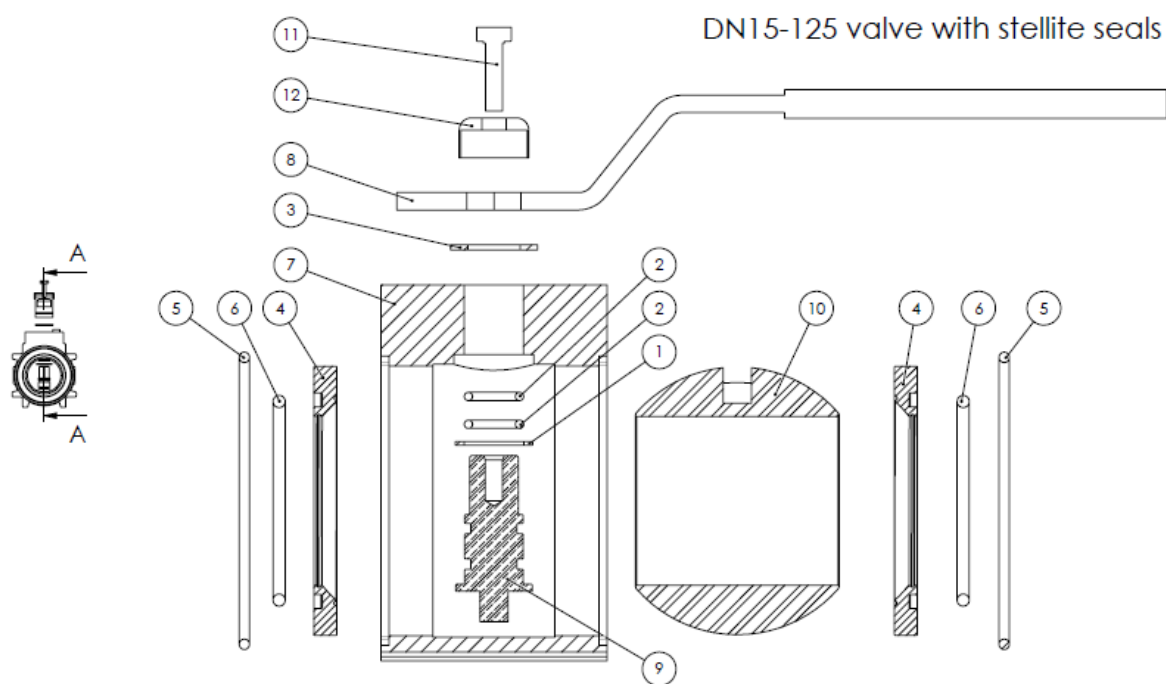

ITEM NO.		QTY.
1	Bearing	1
2	O-ring	2
3	Washer	1
4	Ball seat	2
5	O-ring	2
6	O-ring	2
7	Body	1
8	Hand lever	1
9	Stem	1
10	Ball	1
11	Locking screw	1
12	Cup washer	1



Jouka Oy
Somerotie 4
FIN-33470 Ylöjärvi, Finland

03 359 7500
info@jouka.fi

www.jouka.fi/en/
