

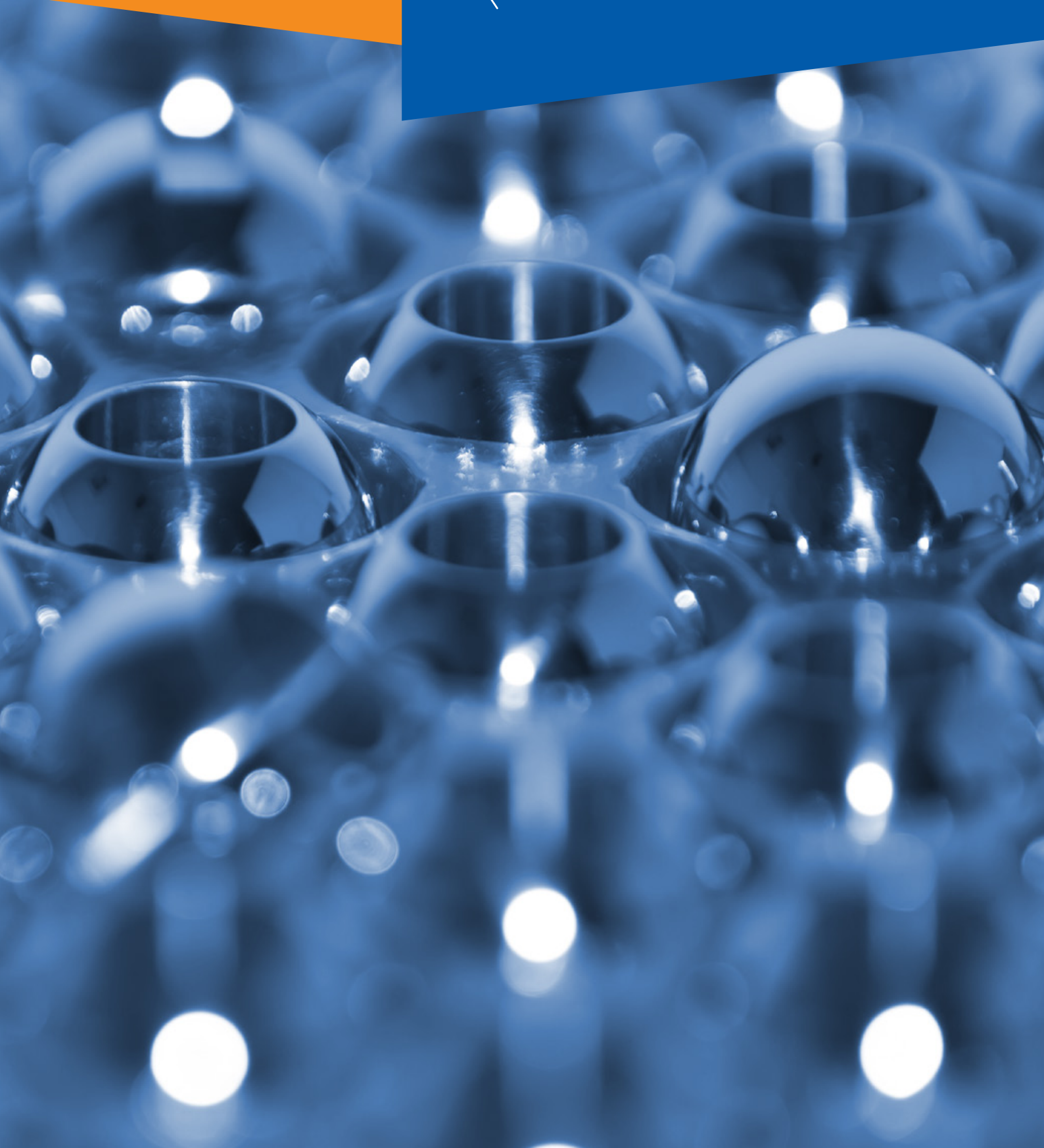

**JOUKA**



**Valves you can trust**

**Ball valves | Actuators**



Quality. Design. Respect .....	3
Process Industry .....	4
Paper Industry.....	5
Marine Industry.....	6
Chemical Industry .....	7
Machinery and Hydraulics .....	8
Vehicles.....	9
LNG .....	10
Tailor-made subcontracting products .....	11
Jouka Joline Actuators .....	12
Valves with actuators.....	13
Aluminium valves .....	14–15
Steel and stainless steel valves .....	16–17
Sample taking valves.....	18
Ball valve type selection .....	19



# Quality

High Quality is a result of continuously improving and long experience.

Established in 1957, Jouka Inc. designs and manufactures a wide range of high-quality ball valves in its Ylöjärvi factory situated near Tampere, Finland. Using feedback and ideas from our customers, we strive to continuously develop the quality of our products. Depending on customer need, we can supply pneumatic, hydraulic and electrical actuators to further enhance the performance of our valves. Jouka also offers subcontracting services for metal pressing, machine part manufacture and deep drawing.

# Design

Valve solutions to meet customer needs using standard valve components.

# Respect

Our relationships with customers, employees and the environment are built on two things: trust and respect.



In accordance with the EU Pressure Equipment Directive (PED), all Jouka valves carry a serial number that allows the valve to be easily traced and contains information on the manufacturing process and the materials used.

Thanks to its lightweight and modular construction, the Jouka aluminum valve is well known as an economical solution.

Jouka manufactures valves from a variety of special materials to meet the needs of our customers. For example, valves can be manufactured from stainless steel, duplex steel or Hastelloy. In addition, Jouka can supply valves fitted with chromium-coated balls for extreme and demanding conditions.

Jouka offers customers full life-cycle support starting from initial design services to the supply of spare parts for even the oldest of valves. A key element of our company philosophy is that Jouka valves must be very easy to service and repair. For example, Jouka valves can be removed from a pipeline without having to remove the flanges.

# Process Industry



Jouka develops and supplies safety valve solutions for the process industry. For over 60 years, Jouka has been helping customers find the most cost-effective tailor-made and standard valve solution for their particular application. For process industry

customers, we supply valves manufactured from duplex steel with a specially designed filler sealing to prevent blockage of the valve housing by the processing medium. Jouka also supplies 3-way and V-drilled valves for process industry applications.

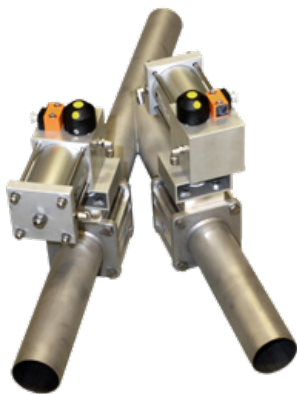

# Paper Industry

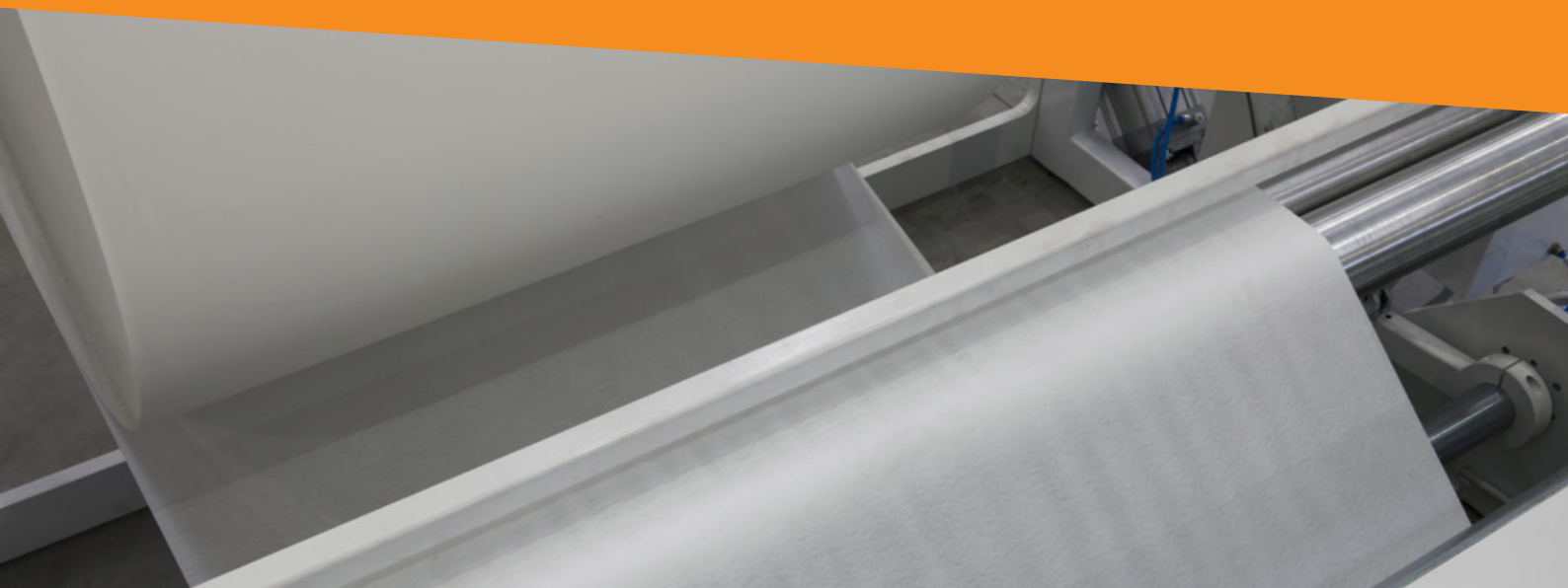

For the paper industry, Jouka delivers sample-taking valves and valves fitted with wear-resistant stellite seals. These robust and reliable valves can be connected directly to a main pipe. Developed especially for use with fibrous media, the stellite seals can also be fitted to standard

valves. Conditions in the paper industry are often demanding with very high temperatures and very abrasive media. To meet these demanding conditions, Jouka supplies valves fitted with stellite seals and hard chrome-plated balls.





# Marine Industry



The extensive material portfolio and the reliable tailor-made valve solutions offered by Jouka are very much appreciated by our customers from the marine and offshore industries. The valves supplied to these industries are manufactured from aluminum, carbon steel, stainless steel, duplex steel, titanium and

elastomeric materials. In the marine industry, valves made from elastomeric plastic are especially suited for applications involving medium salinity seawater. Approval by various classification societies can be sought on customer request.



# Chemical Industry



The materials and seals used in the manufacture of Jouka valves fulfill the requirements of all media used in the chemical industry. Based on our many decades of experience, Jouka valves have been developed to meet the highest quality requirements

of the chemical industry. For demanding chemical industry applications, valves made from special materials such as duplex steel, Hastelloy, titanium and elastomeric plastics are also available.



# Machinery and Hydraulics



Thanks to our many years of experience in the field of machinery and hydraulics, Jouka valves can be tailor-made according to the exact requirements of the customer. Reliability and ease of installation are the key advantages of Jouka valves. To ensure the optimum solution for your application, we provide

different configurations of SAE flanges and hose connectors. In addition, Jouka also manufactures special connectors that can be used for attaching to direct receivers in addition to complete subassemblies.





# Vehicles



For many decades, Jouka aluminum valves have been used in vehicles in Finland and abroad. Jouka aluminum valves are a reliable solution for vehicles where weight and tailored solutions are key drivers. Designed for use with different media, Jouka also

delivers acid-resistant steel valves. For many years, we have manufactured lightweight DN100 aluminum valves fitted with stainless steel or hard chromed-coated balls for very demanding applications such as sewage suction units.

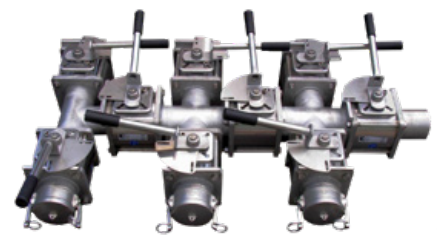



The use of environmentally friendly LNG as a fuel source for tankers and cruise ships is becoming more common. Jouka has kept up with technological advances by manufacturing new valves and manifolds specially designed for the propulsion systems of LNG carriers and LNG terminal applications. Jouka LNG valves are designed to

handle the extensive temperature variations found in demanding LNG applications. Customers can be provided with the relevant certification for Jouka LNG valves and manifolds containing information on traceability, manufacturing process and materials used.



# Tailor-made subcontracting products



With 80 production machines and several hydraulic and mechanical presses, Jouka can provide many kinds of CNC and manual processing, grinding and welding services. Surface finishing and polishing is done with a vibrating grinding machine.

Jouka offers a full range of subcontracting services:

- design, strength calculations, manufacturing and deep drawing
- design and manufacture of tools

To ensure customers always find the best solution for their needs, Jouka is there from the beginning to the very end of the manufacturing process. Delivery times and batch sizes are agreed with customers beforehand. Small batch sizes are also possible.





# Jouka Joline Actuators



Joline	-50	-63	-80	-100
<b>Weight/kg</b>				
1-acting		3,3	6,2	10,8
2-acting	1,1	1,8	3,8	6,1
<b>Torque Nm/5 bar</b>				
1-acting	8	15	30	55
2-acting	20	35	75	150



Joline is an articulated pneumatic actuator for converting linear motion into rotary motion. The actuator is available in both 2-way and 1-way configurations, with spring return. The actuator contains few wear parts, and the joint's large bearing surface extends service life. Its movement is precise and clearance-free.

Operating lifespan approx. 5 million rotations.

A solenoid valve and limit switch can be connected to the actuator.

The actuator can be used to achieve 90° movement in:

- Valves
- Various hatches
- Smoke dampers

# Valves with actuators

We equip valves with actuators according to customer needs. Our range includes pneumatic and electric actuators from various manufacturers, all easy to install on the square shafts of Jouka valves. Standard F-levels enable easy installation and make it possible to convert a manual valve to an actuator valve at a later stage

Inductive or mechanical limit switches and solenoid valves for valve control can be included with an order according to the customer's application. Our range of control ball valves includes positioners from various manufacturers.

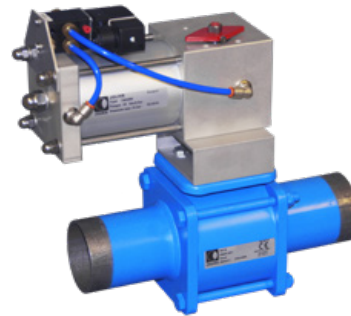

# Aluminium valves

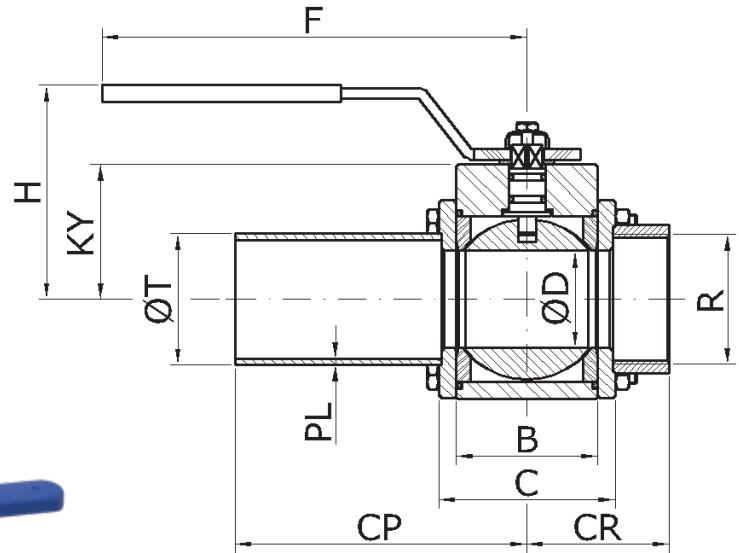

WELDING JOINT

THREAD JOINT

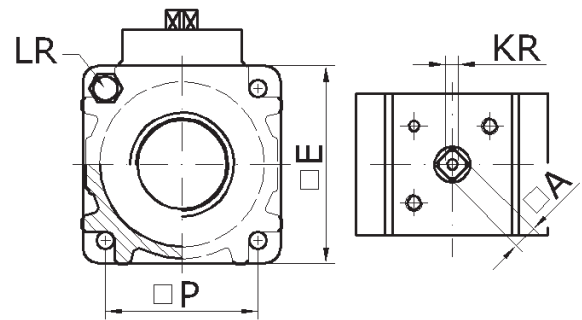

NOMINAL SIZE DN											
mm	in	D	PN	A	B	H	E	F	R	KY	P
20	3/4	25	25	11	36	60	61	150	3/4"	40	46
25	1	25	25	11	36	60	61	150	1"	40	46
32	1 1/4	32	25	11	50	90	74	200	1 1/4"	53	57
40	1 1/2	48,5	25	11	65	100	91	200	1 1/2"	62	70
50	2	48,5	25	11	65	100	91	200	2"	62	70
65	2 1/2	55	16	14/17	77	160	112	260	2 1/2"	74	86
80	3	67	16	14/17	90	165	124	260	3"	81	97
100	4	90	16	14/17	126	190	167	260	4"	106	129
100	4	100	16	14/17	126	190	167	260	4"	106	129



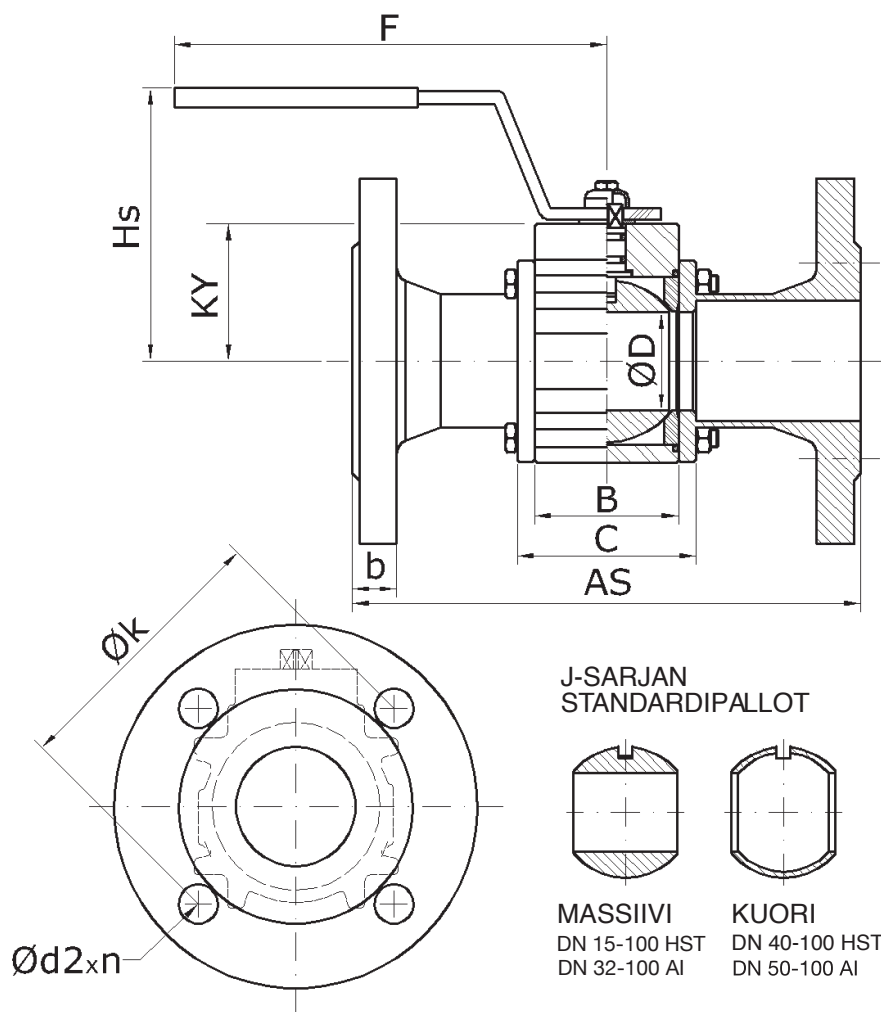

						DIN 2633 PN16					
KR	LR	C*	CP*	PL*	CR*	AS	d2	n	k	b	Hs
M6	M8	52	121	2,3	43	150	14	4	75	18	75
M6	M8	52	121	2,6	46	160	14	4	85	18	75
M6	M8	66	128	2,6	56	180	18	4	100	18	110
M6	M8	81	136	2,6	67	200	18	4	110	18	100
M6	M8	81	136	2,9	69	230	18	4	125	20	100
M8	M10	101	146	2,9	81	290	18	4	145	18	125
M8	M10	114	152	3,2	94	310	18	8	160	20	135
M8	M12	150	170	3,2	117	350	18	8	180	20	130
M8	M12	150	170	3,2	117	350	18	8	180	20	130

\*Measures are normative for steel pipe joints.

# Steel and stainless steel valves

H/K-SERIES  
STANDARD  
BALLS



MASSIVE TYPE  
DN 10-100 HST

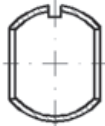

SHELL TYPE  
DN 50 - 300 HST

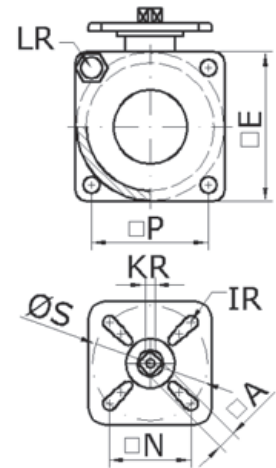
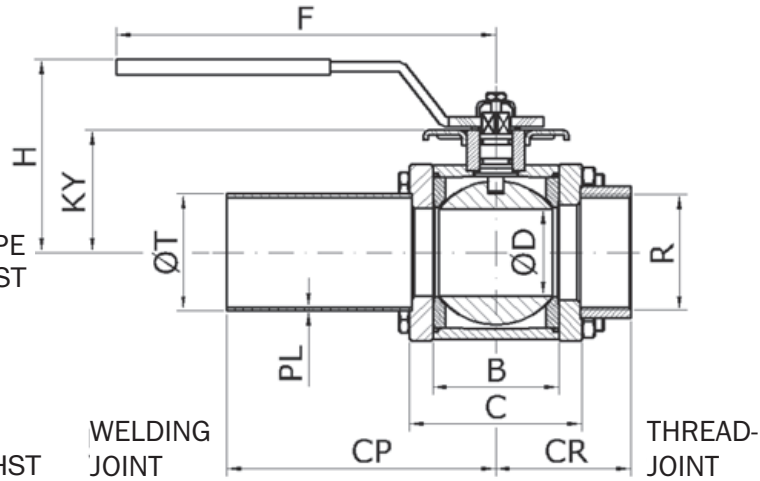

NOMINAL SIZE DN		D	PN	ISO	A	B	H	E	F	R	KY	P	KR	LR	PP	AV
mm	in			5211 F												
10	3/8	15	25	05	11	30	50	47	150	3/8"	31	32	M6	M6	-	-
15	1/2	15	25	05	11	30	50	47	150	1/2"	31	32	M6	M6	-	-
20	3/4	25	25	05	11	36	60	61	150	3/4"	39	46	M6	M8	-	-
25	1	25	25	05	11	36	60	61	150	1"	39	46	M6	M8	-	-
32	1 1/4	32	25	05,07	11	50	90	74	200	1 1/4"	54	57	M6	M8	-	-
40	1 1/2	48,5	25	05,07	11	65	100	91	200	1 1/2"	63	71	M6	M10	-	-
50	2	48,5	25	05,07	11	65	100	91	200	2"	63	71	M6	M10	-	-
65	2 1/2	48,5	16	05,07	11	65	100	91	200	2 1/2"	63	71	M6	M10	-	-
65	2 1/2	55	16	07,10	17	77	165	112	260	2 1/2"	73	86	M8	M10	-	-
65	2 1/2	67	16	07,10	17	90	170	124	260	2 1/2"	81	97	M8	M10	-	-
80	3	67	16	07,10	17	90	170	124	260	3"	81	97	M8	M10	-	-
80	3	80	16	07,10	17	116	185	152	260	3"	94	115	M8	M12	-	-
100	4	80	16	07,10	17	116	185	152	260	4"	94	115	M8	M12	-	-
100	4	90	16	10,12,14	17	126	205	167	310	4"	103	129	M8	M12	-	-
100	4	100	16	10,12,14	22	136	220	202	310	4"	111	-	M8	M12	200	202
125	5	100	16	10,12,14	22	136	220	202	310	-	111	-	M8	M12	200	202
125	5	125	16	10,12,14	22	164	240	235	310	-	132	-	M8	M16	220	235
150	6	125	16	10,12,14	22	164	240	235	310	-	132	-	M8	M16	220	235
150	6	150	16	10,12,14	27	186	315	272	*	-	167	-	M8	M20	272	275
200	8	150	16	10,12,14	27	186	315	272	*	-	167	-	M8	M20	272	275
200	8	200	16	10,12,14	27	242	351	366	*	-	206	-	M8	M20	351	366

\*hand wheel with gear

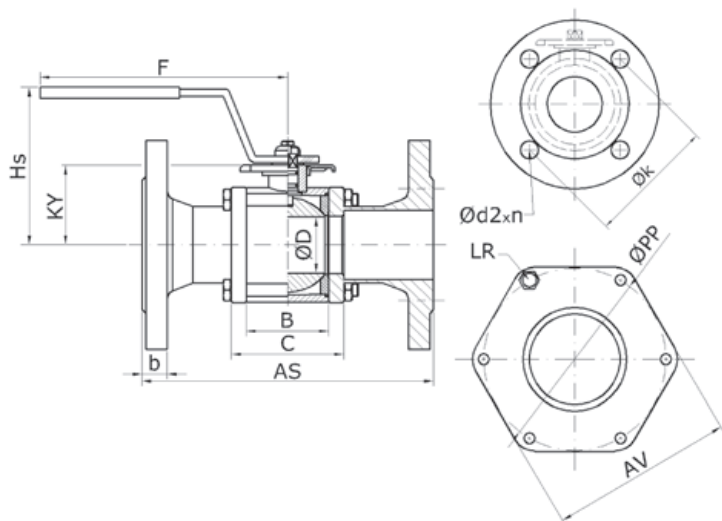

ISO 5211	IR	N	S
F05	M6	35,4	50
F07	M8	49,5	70
F10	M10	72,1	102
F12	M12	88,4	125
F14	M16	99	140

R = inside thread  
P = welding joint, long (standard)  
D = DIN-flange  
O = middle part (without joints)

C*	CP*	CR*	PL		DIN						WEIGHTS (Kg)				NOMINAL SIZE DN	
			H	K	AS	d2	n	k	b	Hs	R	P	D	O	mm	in
42	115	45	1,6	2	130	14	4	60	16	70	0,6	0,7	2,0	0,4	10	3/8
42	115	35	1,6	2	130	14	4	65	16	70	0,7	0,7	2,2	0,4	15	1/2
51	120	42	1,6	2,3	150	14	4	75	18	80	1,4	1,5	3,6	0,7	20	3/4
52	120	45	1,6	2,6	160	14	4	85	18	80	1,4	1,6	4,0	0,7	25	1
66	127	54	1,6	2,6	180	18	4	100	18	115	2,4	2,6	5,5	1,0	32	1 1/4
85	137	64	1,6	2,6	200	18	4	110	18	125	3,5	4,0	8,3	2,0	40	1 1/2
85	137	68	1,6	2,9	230	18	4	125	20	125	3,5	4,1	9,4	2,0	50	2
85	137	72	1,6	2,9	290	18	4	145	18	125	3,7	4,2	11,2	2,0	65	2 1/2
101	145	80	1,6	2,9	290	18	4	145	18	165	6,3	7,0	13,6	3,7	65	2 1/2
114	151	86	1,6	2,9	290	18	4	145	18	170	8,6	9,6	16,4	5,1	65	2 1/2
114	151	89	2	3,2	310	18	8	160	20	170	8,6	9,6	18,5	5,1	80	3
140	164	102	2	3,2	310	18	8	160	20	185	14,3	15,1	22,5	10,3	80	3
140	164	102	2	3,6	350	18	8	180	20	185	14,3	15,1	24,6	10,3	100	4
158	173	111	2	3,6	350	18	8	180	20	205	20,0	19,8	29,3	12,5	100	4
168	177	116	2	3,6	350	18	8	180	20	220	23,5	23,3	32,8	15,4	100	4
168	177	-	2	4	400	18	8	210	22	220	-	23,3	36,5	15,4	125	5
204	196	-	2	4	400	18	8	210	22	240	-	-	51,8	25,7	125	5
204	196	-	2	4,5	480	22	8	240	22	240	-	-	53,7	25,7	150	6
226	207	-	2	4,5	480	22	8	240	22	315	-	-	80,7	44,3	150	6
226	207	-	2	6,3	457	22	12	295	24	315	-	-	87,2	44,3	200	7
282	236	-	2	6,3	457	22	12	295	24	315	-	-	115	48,0	200	7

\*Measures are normative for steel pipe joints.



# Sample taking valves

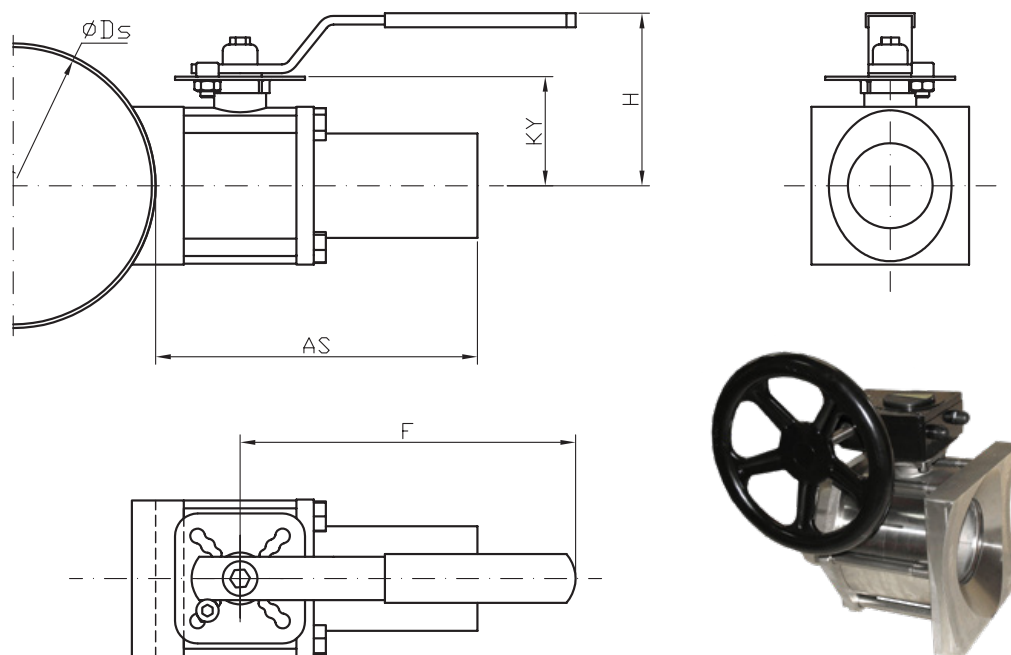

NIM SIZE	DN	FLOW PORT D	PN	ISO 5211 F	A	AS	E	F	H	KY	T
mm	in	$\phi$									
10	3/8	15	25	05	11	140	47	150	50	31	17,2
15	1/2	15	25	05	11	150	47	150	50	31	21,3
20	3/4	25	25	05	11	150	61	150	60	39	26,9
25	1	25	25	05	11	150	61	150	60	39	33,7
32	1¼	32	25	05, 07	11	170	74	200	90	54	42,4
40	1½	48,5	25	05, 07	11	185	91	200	100	63	48,3
50	2	48,5	25	05, 07	11	185	91	200	100	63	60,3
65	2½	48,5	25	05, 07	11	185	91	200	100	63	76,1
65	2½	55	16	07, 10	17	200	112	260	165	73	76,1
65	2½	67	16	07, 10	17	215	124	260	170	81	76,1
80	3	67	16	07, 10	17	215	124	260	170	81	88,9
80	3	80	16	07, 10	17	240	152	260	185	94	88,9
100	4	80	16	07, 10	17	240	152	260	185	94	114,3
100	4	90	16	10, 12, 14	17	255	167	310	205	103	114,3
100	4	100	16	10, 12, 14	22	265	202	310	220	111	114,3
125	5	100	16	10, 12, 14	22	265	202	310	220	111	139,7
125	5	125	16	10, 12, 14	22	300	235	310	240	132	139,7
150	6	125	16	10, 12, 14	22	300	235	310	240	132	168,3
150	6	150	16	10, 12, 14	27	325	272	▣	▣	167	168,3
200	8	150	16	10, 12, 14	27	325	272	▣	▣	167	219,1
200	8	200	16	10, 12, 14	27	380	366	▣	▣	206	219,1

Ds = Dimension given with order | A = Square size of shaft | As-dimension (+5) | ▣ = Manual use  
 T = pipe outline diameter | E = body height / width

**BALL MATERIAL:**

- A = Aluminium
- H = Stainless steel (AISI 316)
- K = Hard chrome plated ball, only DN100/090
- T = Titanium
- M = Plastic (POM), other material marked with "E"
- D = Duplex (2205 / EN 1.4462)
- SD = SuperDuplex (2507 / EN 1.4410)
- R = Stainless steel (304L / EN 1.4307)

**O-RING MATERIAL:**

- V = FPM (Viton) (Jouka standard)
- E = EPDM (Ethylene propylene)
- N = NBR (Nitrile)
- P = FFKM (Perlast / Kalrez)
- A = FEPM (Aflas)
- SA = stellite ball seals, FEPM (Aflas) O-rings
- SP = stellite ball seals, FFKM (Perlast/Kalrez) O-rings
- T = PTFE (Teflon)

**FLOW PORT DIAMETER:**

Flowport diameter (marked with three numbers)

**JOINTS:**

- R = inside thread R (BSP)
- RU = outside thread
- P = welding joint, long (standard)
- D = DIN-flanges, D1=PN16, D2=PN25, D4=PN40
- O = without joints, ball valve middle part + bolts/nuts
- C = camlock hose joint
- L = Hose mandrel
- A = Sample taking valve

Different joints are marked with slash, P/L = welding joints / Hose mandrel. Manual hand lever is installed to point to towards joint after slash in open position.

If the letter is followed by an "H", the part is AISI316, "T" titanium, "A" aluminium.

**H080/067HVP-.....-.....-.....-.....**

**NOMINAL SIZE OF VALVE:**

DN-size (marked with three numbers)

**BODY MATERIAL:**

- J = Aluminium
- M = Plastic (POM), other material marked with "E"
- H = Stainless steel (AISI 316), other materials marked with "E"
- K = Steel
- T = Titanium
- D = Duplex (2205 / EN 1.4462)
- SD = SuperDuplex (2507 / EN 1.4410)
- R = Stainless steel (304L / EN 1.4307)

**ADDITIONAL INFORMATION:**

- V = Hand lever, galvanized steel (H-series valves always stainless steel)
- VH = hand lever stainless steel (stainless steel, standard in H-series)
- T = Actuator version, shaft size (mm)
- PP = Solid, massive type ball
- G = Ball seals, fibreglassed PTFE
- C = Ball seals PTFE+C (25 % carbon)
- NS = Metric dimension pipe
- E = special design, see specification
- PPCr = Hard chrome coated ball
- V(L) = lockable manual handle, galvanized steel
- VH(L) = lockable manual handle, stainless steel
- P = PEEK ball seat

**3-WAY VALVE:**

- 3P = Third joint opposite the shaft (bottom)
- 3S = Third joint at the side

**BALL MODEL:**

- L = L-shaped
- T = T-shaped
- S = Sector

**3PLH080...**

**Jouka Inc.**

Somerotie 4  
FIN-33470 Ylöjärvi, FINLAND  
Tel. +358 3 359 7500  
info@jouka.fi

**jouka.fi/en**

# **JOUKA**

Valves you can trust

